



FIRE & GAS DETECTION TECHNOLOGIES INC.

User Manual



FlameSpec UV-IR FlameSpec UV-IR-F

FlameSpec-UV-IR UV/IR Flame Detector User Guide, February 2019

Copyright © Fire & Gas Detection Technologies Inc. All rights reserved.

The owner or authorized user of a valid copy of this manual may reproduce this publication for the purpose of learning to use the specified equipment. No part of this publication may be reproduced or transmitted for commercial purposes, such as selling copies of this publication or for providing paid for support services.

The Fire & Gas Detection Technologies logo is a trademark of Fire & Gas Detection Technologies Inc., registered in the U.S. and other countries.

Every effort has been made to ensure that the information in this manual is accurate. However, Fire & Gas Detection Technologies Inc. is not responsible for any inaccuracy or omission in this document. The information in this document is subject to change without notice.

Table of Contents

1. Introduction	1
1.1 Key Features	1
1.2 Model Number Description	2
1.3 Internal tests	2
2 Installation	3
2.1 General Considerations	3
2.2 Preparations for Installation	5
2.3 Required Tools	5
2.4 Certification Instructions	5
2.5 Installing the Tilt Mount	7
2.6 Installing the detector	8
3 Configuration options	10
3.1 Sensitivity	10
3.2 Ultra-Fast Detection	11
3.3 Alarm Delay	11
3.4 Alarm Latch	11
3.5 Window Heater	11
3.6 Modbus Address	11
3.7 Manual BIT – Alarm Output Test	11
4 Detector Wiring	12
4.1 Wiring Functions:	12
4.2 Current Output (0-20mA) Wiring	13
4.3 RS-485 Communication Network	15
5 Operation	16
5.1 Output Signals	16
5.2 Testing	17
5.3 Maintenance	17

5.4	Troubleshooting	18
6	Specifications.....	19
6.1	Fire Detection	19
6.2	Electrical Specifications	19
6.3	Outputs	19
6.4	Mechanical Specifications	20
6.5	Environmental Specifications	20
6.6	Label Figures.....	21
6.7	Approvals	22
6.8	Electromagnetic Compatibility	22
7	Warranty.....	23
Appendix A Response Characteristics FLS-UV-IR.....		24
A.1	Response to different fire scenarios	24
A.2	False Alarm Immunity	26
Appendix B Response Characteristics FLS-UV-IR-F		27
B.1	Response to different fire scenarios	27
B.2	False Alarm Immunity	28

List of Figures

Figure 1: Tilt Mount Base - Rear View	7
Figure 2: Tilt mount base – Side View.....	8
Figure 3: Detector on Tilt Mount – Side View.....	9
Figure 4 – Source 4-Wire Scheme.....	13
Figure 5 – Sink 4-Wire Scheme	13
Figure 6 – Source 3-Wire Scheme.....	14
Figure 7 – Sink 3-Wire Scheme	14
Figure 8: RS-485 Networking	15

List of Tables

Table 1: Detector Configuration Options.....	10
Table 2: Sensitivity levels	10
Table 3: Terminal connections.....	12
Table 4: Output Signals.....	16

1. Introduction

The **FlameSpec-UV-IR** flame detector provides ultra-fast response, high performance and reliable detection of a large variety of fires including hydrocarbon fires (visible and non-visible), as well as hydrogen fires (FLS-UV-IR only).

The detector addresses slow growing fires as well as fast eruptions of fire using improved UV-IR technology.

The detector operates in all weather and light conditions. It will automatically record a fire event (1 min pre/post alarm) using the internal data logger.

This manual covers two UV/IR detector models:

1. **FLS-UV-IR:** Hydrogen and hydrocarbons flame detection. Spectrum response of IR radiation in the 3.0-4.0 micron range
2. **FLS-UV-IR-F:** Hydrocarbon flame detection. Spectrum response of IR radiation in the 4.0-5.0 micron range

1.1 Key Features

- **High immunity: To false alarm**
- **Ultra-fast detection mode:** Within 5 milliseconds for Hydrogen fireballs or explosions
- **High sensitivity:** Up to 100 ft. (30m) for a 1ft² (0.1m²) n-heptane pan fire
- **Built-in-Test (BIT)** - Automatic and manual self-test of window cleanliness and the overall operation of the detector.
- **Window heater** to avoid condensation and icing.
- **Tilt mounting bracket** can be connected either above or below the detector.
- **UV and IR warning levels - 0-20mA** - current output warning when elevated UV or IR radiation is detected.

1.2 Model Number Description

Model No are defined as follows:

FLS-UV-IR-F - X S X 1

FLS-UV-IR - X S X 1

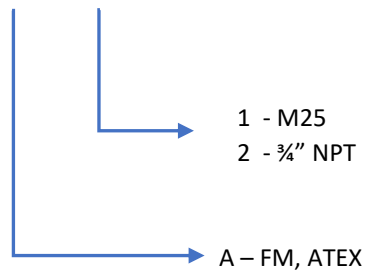

1.3 Internal tests

During normal operation, the flame detector performs self-tests of its optics, electronics and software. These include a periodic BIT (Built-In-Test) in which the sensors and window cleanliness are tested. Any detected fault is indicated as shown in Table 4 (in section 5.1). During "Dirty Window" fault the detection sensitivity is significantly reduced, while "Fault" refers to critical faults which totally prevent flame detection.

2 Installation

The detector is intended for use as part of a complex system where many detectors and other devices are integrated with different vendors' systems and interface communication to a variety of different types and configuration control units and panels including control of instrumentations computers. This chapter does not attempt to cover all of the standard practices and codes of installation. Rather, it emphasizes specific points of consideration and provides some general rules for qualified personnel. You must always observe special safety precautions.

2.1 General Considerations



This section includes important information.

To help obtain optimal performance, the detector should be aimed toward the center of the hazard or area to be monitored and protected ("detection zone") and have, to the extent that is required, an unobstructed view of the protected area. Whenever possible, the detector face should be tilted (aimed) down at an angle to prevent the accumulation of dust and dirt.

Do not start an installation until the detector task definition, system configuration, installation location and coverage considerations have been considered and clearly defined by the relevant designers.

To ensure optimal performance and an efficient installation that fits your needs and complies with the requirements, the following guidelines should be addressed:

Sensitivity

To determine the sensitivity level, the following issues should be considered:

- The size of the fire to be detected at the determined distance.
- The type of flammable fuel.

Spacing and Location

Consider the following factors when determining the number of detectors and their locations in the protected area:

- The size and shape of the protected area
- The nature of the hazards, including materials stored or used and the protected objects
- The sensitivity of the detectors
- If there are any obstructed lines of sight
- The field of view of the detectors

Environment

- Environmental conditions including but not limited to dust, snow or rain can reduce the detectors sensitivity and require additional maintenance.

Welding

- Arc welding should not be performed within 10 ft. (3m) of the detector. It is recommended that the system be inhibited during welding operations in situations where the possibility of a false alarm cannot be tolerated.
- Gas welding requires a system inhibit, since the gas torch is an actual fire.
- Arc welding rods can contain organic binder materials in the flux that burn during the welding operation and are detectable by the device.
- Welding rods with clay binders do not burn and should not be detected. However, a system inhibit is always recommended, since the material being welded may be contaminated with organic substances (paint, oil, etc.) that will burn and may be of the size that should be detected.

2.2 Preparations for Installation

The installation must comply with local regulations and standards applicable to flame detectors (e.g., NFPA 72) and all local and common engineering practices. It is recommended to consult with a safety engineer.

The detectors can be installed with the use of general-purpose common tools and equipment.

Prior to installation:

- Verify the appropriate purchase order.
- Record the part and serial numbers of the detectors and the installation date and log.
- Visually inspect the detector prior to installation to make sure it is intact.
- Make sure that you have all the components and tools required to complete the detector installation readily available before beginning installation. In cases where you cannot complete the installation in a single session, secure and seal the detectors and conduits before leaving the site.
- Use color-coded conductors or suitable wire markings or labels for the wiring. You may use 12 to 20 AWG (2.5 mm² to 0.35 mm²) wires for the site wiring. The selection of wire gauge should be based on the number of detectors used on the same line and the distance from the control unit, in compliance with specifications.
- Use wire rated for a temperature of at least 111°C, which is 5°C above the rated service temperature.

2.3 Required Tools

The detector can be installed using general purpose common tools as defined in the following table:

Tool	Function
Hex. KEY 6 mm	Vertical alignment
Hex. KEY 10 mm	Horizontal alignment
Wrench 13 mm	Mounting the detector
Flat Screwdriver 6 mm	Ground screw connection
Flat screwdriver 3.5mm	Terminal connection

2.4 Certification Instructions



Warning: Do not open the detector, even when isolated, when flammable atmosphere present.

- The equipment may be used in hazardous areas with flammable gasses and vapors with apparatus groups IIC, IIB and IIA and with temperature classes T1, T2, T3, T4 and T5. See details of the explosion proof approvals in section 6.6.1.
- The equipment is certified for use in ambient temperatures in the range of -67°F to +167°F (-55°C to +75°C) or -67°F to +185°F (-55°C to +85°C) and should not be used in temperatures outside this range.

- Installation shall be carried out in accordance with the applicable code of practice by suitably trained personnel.
- Inspection and maintenance of this equipment shall be carried out by suitably trained personnel in accordance with the applicable code of practice.
- If the equipment is likely to come into contact with corrosive and other harsh substances, consult with the relevant technical persons to take suitable precautions to prevent the detector from being adversely affected, thus ensuring that the type of protection is not compromised.
- Harsh substances: For example, acidic liquids, gases, or solvents that may attack the lens, metals, seals or polymeric materials.
- Suitable Precautions: For example, regular checks as part of routine inspections or establishing from the material's data sheet that it is resistant to specific chemicals.

2.4.1 Specific conditions for use

- The equipment is not intended to be repaired by the user. Repair of this equipment shall be carried out by the manufacturer in accordance with the applicable code of practice.
- The flameproof joints are not intended for repair. Contact the manufacturer if the flameproof joints are damaged.
- Consult the manufacturer for genuine replacement cover and housing to connection box fasteners. M6x1x18 Hexagonal Socket head fasteners with a minimum of ISO 4762 Grade A4 Class 80 are acceptable alternatives.
- One stopping plug is supplied with the detector and is suitably certified.
- The external earthing connection consists of cable lug with M5x10 stainless steel screw, the terminals is suitable for connection of a wire of at least 4 mm^2 .
- The internal terminals are suitable for connection of a wire equal to or greater than the power input wiring and at a minimum of 1 mm^2 conductor.

2.5 Installing the Tilt Mount

The tilt mount enables the detector to be rotated up to 45 degrees (horizontal/vertical) in all directions. The following installation instructions show how to use it to support the detector from below (the preferred method). However, with a designated adapter the tilt mount can hold the detector from above. Other designated adapters may be used to connect the detector to some other vendors' tilt mounts (useful when replacing an existing detector).

To install the tilt mount:

- a) Place the tilt mount (Fig. 1) in its designated location and secure it with four screws through four 0.28" (7mm) diameter holes. There are four captive screws with spring washers in the tilt mount. The following drawing shows the location of the four holes for the screws and washers.

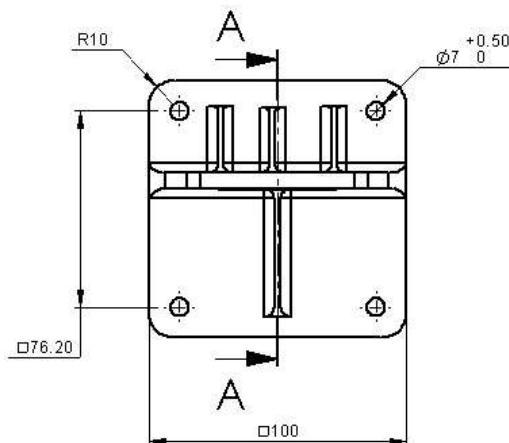

Figure 1: Tilt Mount Base - Rear View

The following drawing is a side view of the tilt mount:

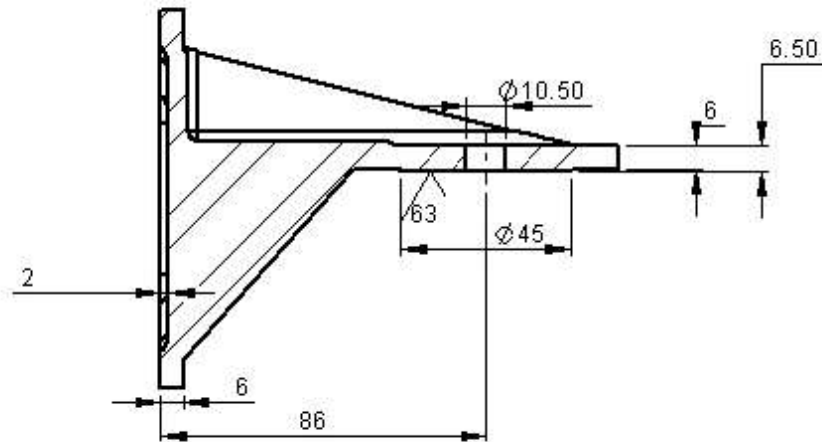

Figure 2: Tilt mount base – Side View

2.6 Installing the detector

Use the following steps to connect the detector to the tilt mount, referring to Figure 3:

- a) Unpack the detector
- b) Place the detector, with its connector or cable pointing down, on the holding plate of the tilt mount (item 2).
- c) Secure the detector by using the two provided screws and spring lock washers (Items 3 and 4).
- d) Release the locking screws (Items 5 and 6) in such a way that enables you to rotate the detector.
- e) Point the detector towards the detection area and make certain that the view of the area is unobstructed.
- f) Secure the detector in that position by tightening the locking screws (Items 5 and 6) on the tilt mount. (Make sure the detector is in the correct position).

The detector is now correctly located, aligned and ready to be connected to the system. Please refer to section 0 for wiring instructions, and section 3 for a description of the detector's configuration settings.

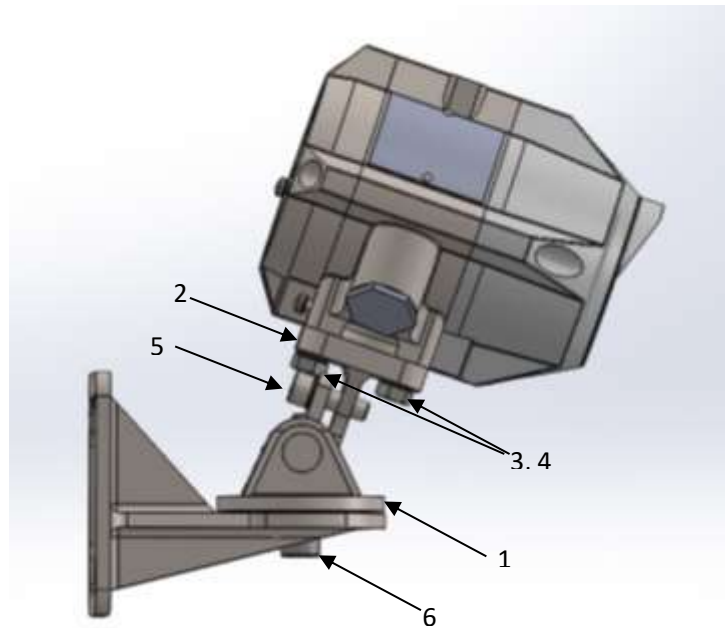

Figure 3: Detector on Tilt Mount – Side View

ITEM NO.	ITEM NAME
1	TILT MOUNT ASSEMBLY
2	HOLDING PLATE
3,4	MOUNTING HEX SCREWS M8 AND LOCK WASHERS
5	HEX SOCKET LOCKING SCREW M8
6	HEX SOCKET LOCKING SCREW M12

3 Configuration options

Some functions of the detector can be configured using an RS-485 modem connected to a computer with the “FDG communicator” software. These configuration options are listed in the following table along with their factory default values.

TABLE 1: DETECTOR CONFIGURATION OPTIONS

Function	Options	Default Setting
Sensitivity	Low, Medium, High, Extreme	Medium
Ultra-fast detection	Disabled, Enabled	Disabled
Alarm Delay	0, 5, 10, 20 or 30 seconds	0 seconds (no delay)
Alarm Latch	Disabled, Enabled	Disabled
Window Heater	Disabled, Enabled	Enabled
Modbus address	1 – 247	1
Manual BIT – Alarm Output Test	Disabled, Enabled	Disabled

- Note: Medium sensitivity setting allows detection of a 1x1ft² (0.1m²) N-heptane pan fire at a distance of 33ft (10m).

3.1 Sensitivity

The detector can be configured to one of four sensitivity levels: low, medium, high and extreme. The following table lists for each sensitivity setting the maximum distance, in which a standard fire¹ would be reliably detected.

TABLE 2: SENSITIVITY LEVELS

Sensitivity level	Detection distance in feet (meters)
Low	17 (5)
Medium	33 (10)
High	67 (20)
Extreme	97 (30)

¹ A standard fire is defined as a 1x1 ft² (0.1 m²) N-heptane pan fire, with maximum wind speed of 6.5 ft/s (2 m/s).

Further details about the response characteristics of the detector at the different sensitivity settings can be found in Appendix A.

3.2 Ultra-Fast Detection

The ultra-fast detection feature allows detection of fireballs and explosions at 5 milliseconds. This feature can be disabled or enabled regardless of the alarm delay configuration.

3.3 Alarm Delay

When a flame is detected, the flame detector delays the execution of the alarm outputs by the configured time period. After this time delay, the detector re-evaluates the situation. If a flame is still detected the alarm outputs are activated.

3.4 Alarm Latch

If alarm latch is enabled, the detector outputs will remain in alarm mode even after a flame is no longer detected. To return the detector outputs to normal mode the detector must be powered down and restarted.

3.5 Window Heater

The detector is equipped with a heater to prevent condensation and icing on the window. If enabled, the heater is operated automatically depending on temperature.

3.6 Modbus Address

The detector can communicate with the “FGD communicator” software using a Modbus RTU compatible protocol on RS-485. This protocol allows for a network of detectors to be connected, each with a unique Modbus address. The address of the detector can be set to any value in the range 1–247.

3.7 Manual BIT – Alarm Output Test

When enabled, the alarm outputs are activated when a **Manual BIT** is initiated. See section 5.2 – “Testing” for details.



Make sure to disable all fire extinguishing actions or alarms connected to the detector when the manual BIT is initiated and the “Manual BIT – Alarm Output Test” is enabled as the Manual BIT will set the 0-20mA terminal to 20mA and close the alarm relay.

4 Detector Wiring



WARNING

The sensor module in the front half of the detector contains no serviceable components and should never be opened. The terminal compartment at the back is the only part of the housing that should be opened by the user.

4.1 Wiring Functions:

The detector has 20 terminals as defined in the following table:

TABLE 3: TERMINAL CONNECTIONS

Pin #	Function	Description
Ground	Ground (earth)	Connected to a screw on the housing exterior.
1	24 VDC (+)	Power supply (18-32 VDC)
2	24 VDC (-)	Power supply return (0V)
3	0-20mA+ (In)	This output is used for analog 0-20 mA current output
4	0-20mA- (out)	
5	Fault Relay	A normally open SPST contact relay, that is energized (closed) when the detector is in normal operation, and opens in case of fault.
6	Fault Relay COM	
7	Alarm Relay (NO)	A normally open SPST contact relay, that is open in normal operation, and closed when fire is detected. This relay can be configured to latch as described in section (3.4).
8	Alarm Relay COM	
11	24 VDC (+)	Power supply (18-32 VDC)
12	24 VDC (-)	Power supply return (0V)
13	Manual BIT activation	The manual BIT (built-in test) can be initiated by momentarily short circuiting this terminal and one of the "24 VDC (-)" terminals (2 or 12). See 3.7 Manual BIT – Alarm Output Test for more details.
14	Shield	This terminal should be left connected to the housing internal ground screw.
15	RS 485 (+)	RS-485 Modbus communication (used by the "FGD Communicator" software)
16	RS485 (-)	
17	Fault Relay (NC)	
18	Alarm Relay (NC)	

4.2 Current Output (0-20mA) Wiring

The detector's 0-20mA current output can act as both a source or a sink transmitter and can be 3-wire or 4-wire connected.

The following drawing shows how to wire the detector to act as a current source isolated transmitter (4-wire connection):

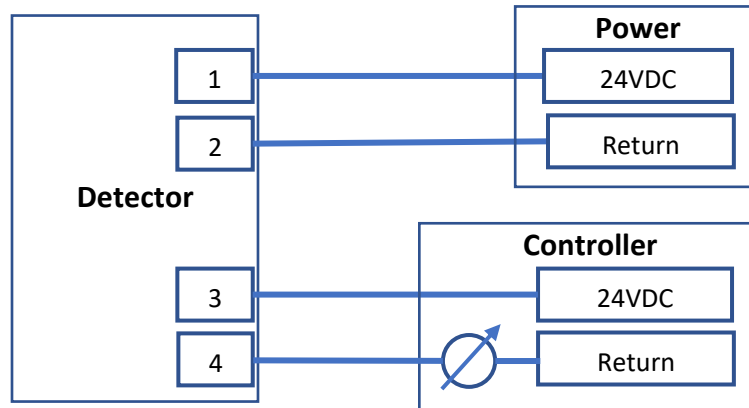

FIGURE 4 – SOURCE 4-WIRE SCHEME

The following drawing shows how to wire the detector to act as a current sink isolated transmitter (4-wire connection):

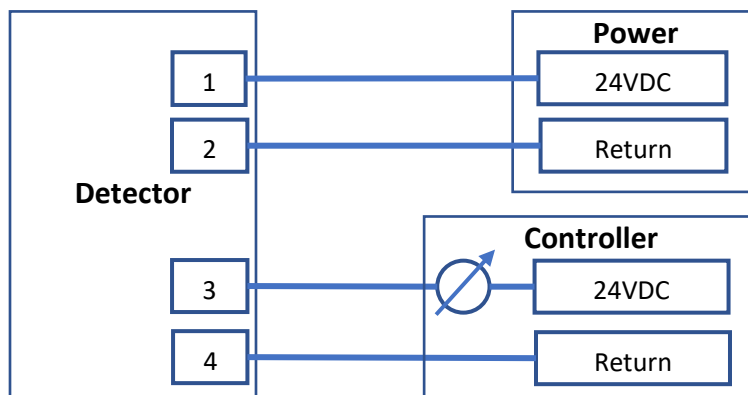

FIGURE 5 – SINK 4-WIRE SCHEME

The following drawing shows how to wire the detector to act as a current source non-isolated transmitter (3-wire connection):

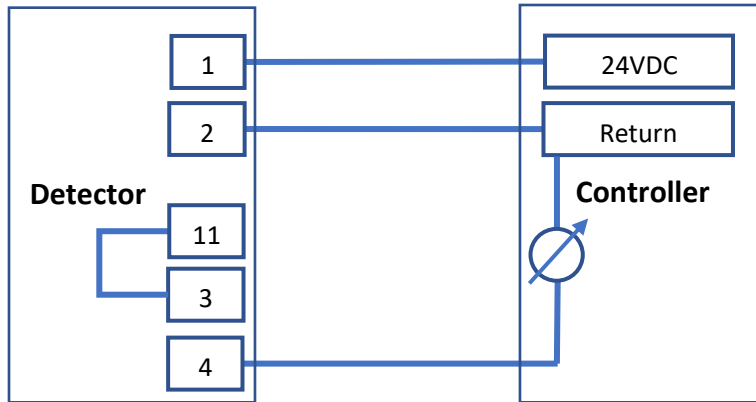

FIGURE 6 – SOURCE 3-WIRE SCHEME

The following drawing shows how to wire the detector to act as a current sink non-isolated transmitter (3-wire connection):

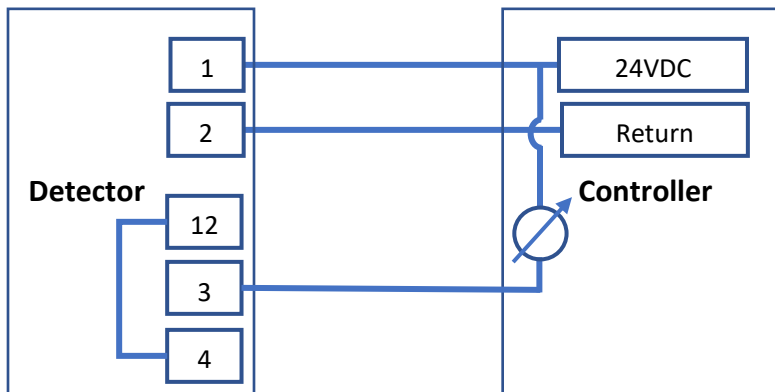

FIGURE 7 – SINK 3-WIRE SCHEME

4.3 RS-485 Communication Network

Using the RS-485 network capability of the detector and communicator software, it is possible to connect up to 32 detectors in an addressable system with 4 wires only (2 for power and 2 for communication). Using repeaters, the number of detectors can be much larger (32 detectors for each repeater) up to 247 on the same 4 wires. Using the RS-485 network, it is possible to read each detector's status (fault, alarm) and to initiate a BIT to each detector individually.

The detector communicates via RS-485 with a Modbus RTU compatible protocol. For more details on the communication protocol, please consult with FGD.

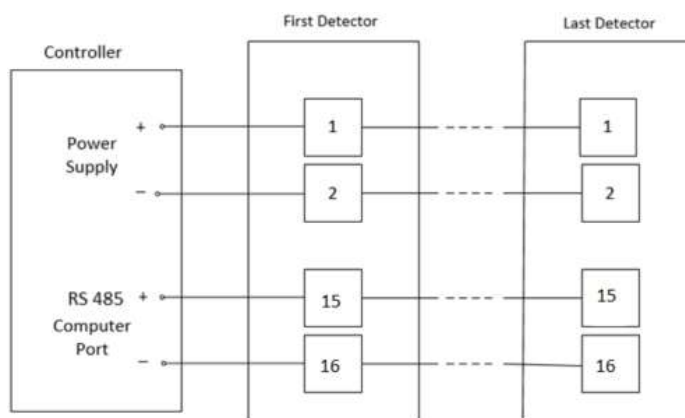

Figure 8: RS-485 Networking

5 Operation

The FlameSpec-UV-IR is a UV/IR flame detector ready for detecting fire approximately 30 seconds after power up. During this startup time the LED flashes Yellow. If the startup is successful, the indication LED turns to green, the 0-20mA indicates 4mA and the fault relay is closed.

Detector configuration settings can be changed as described in section 3.

To restart the detector, turn off and then turn on the power.

5.1 Output Signals

The detector has the following output signals:

- Current output (0–20mA)
- Relays (Fault and Alarm)
- RS-485
- Tri-color LED

TABLE 4: OUTPUT SIGNALS

	Startup	Fault	Dirty Window	Normal	IR radiation detected	UV Radiation detected	Fire Alarm
0 – 20mA	1mA	1mA	2mA	4mA	8mA	12mA	20mA
Fault Relay (NO)	Open	Open	Open	Closed	Closed	Closed	Closed
Alarm Relay NO	Open	Open	Open	Open	Open	Open	Closed
LED	Flashing Yellow	Flashing Yellow	Yellow	Green	Green	Green	Red

5.2 Testing

The detector has a Built-In-Test (BIT) capability to ensure proper operation and to make sure that the window is not dirty. The BIT process runs automatically at startup and periodically during the operation of the detector. The BIT can also be initiated manually by short circuiting the “Manual BIT” terminal and the “24 VDC (-)” terminal for one second (see Table 3) or by using the FGD communicator software (connected through RS-485).

In case of “Dirty Window” fault the detector may still detect flames but at a lower sensitivity.

When “Manual BIT – Alarm Output Test” feature is enabled (see section 3.7), a successful Manual BIT will activate the following alarm outputs for a few seconds:

1. The led in the front of the detector will turn red.
2. The 0-20mA current output will be set to 20mA.
3. The alarm relay will close.



WARNING

Make sure to disable all fire extinguishing actions or alarms connected to the detector, when the manual BIT is initiated and the “Manual BIT – Alarm Output Test” is enabled, as the manual BIT will set the 0-20mA terminal to 20mA and close the alarm relay.

5.3 Maintenance

After powering up, the detector should work maintenance free with the exception of optical window cleaning and an annual fire detection operational test.



WARNING

The sensor module in the front half of the detector contains no serviceable components and should never be opened. The terminal compartment at the back is the only part of the housing that should be opened by the user.

Any violation of these instructions will invalidate the warranty.

5.3.1 Cleaning Procedure

To clean the detector:

- a) Disconnect the power to the unit and disable/inhibit any extinguishing equipment that is connected to the unit.
- b) Use water and detergent to clean the detector viewing window and reflector. Rinse with a soft cloth, cotton swab, or tissue.

- c) Where dust, dirt or moisture accumulates on the window, first clean the window with a soft optical cloth and detergent, and then rinse with a clean soft cloth, cotton swab, or tissue.

5.4 Troubleshooting

In case of problem in the operation of the detector, please consult with the following table before calling for help:

Problem	Possible Cause	Corrective Action
LEDs Off Fault Relay is open Current output at 0mA	No power to the unit	<ul style="list-style-type: none"> • Check that the power is connected to the detector. • Check power polarity. • Check wiring in the detector.
Yellow LED constantly on Fault Relay is open Current output at 0mA	Power problems	Check the voltage between the "24VDC (+)" and "24VDC (-)" terminals to verify that it is in the allowed range (see section 6.2)
Yellow LED constantly on Fault Relay is open 0–20mA at 2mA	BIT Fault	<ul style="list-style-type: none"> • Clean detector window. • Restart the detector (by turning the power off and then back on).
Red LED constantly on	Detector is in alarm latch mode	Restart the detector (by turning the power off and then back on).
Alarm Relay closed and current output is at 20mA	Detector is exposed to a flame	<ul style="list-style-type: none"> • Check cause of alarm. • If caused by "friendly fire", reposition the detector so that it is not affected by it.

6 Specifications

6.1 Fire Detection

- Detection time and distance:
 - FLS-UV-IR:
 - 5ms - for fast fire burst or explosion
 - 1s - for 1ft² (0.1m²) N-heptane pan fire at 0-50 ft (0-15m)
 - <2s - for 1ft² (0.1m²) N-heptane pan fire at 50-100 ft (15-30m)
 - FLS-UV-IR-F
 - 5ms - for fast fire burst or explosion
 - 1.5s - for 1ft² (0.1m²) N-heptane pan fire at 0-50 ft (0-15m)
 - <3s - for 1ft² (0.1m²) N-heptane pan fire at 50-100 ft (15-30m)
- Field of view: 90° Horizontal, 80° Vertical
- Time Delay: 0-30 seconds (adjustable)
- Built-in test: Automatic and Manual

6.2 Electrical Specifications

- Operating Voltage: 24 VDC nominal (18-32 VDC)
- Current Consumption:
 - Standby 120mA
 - Maximum 180mA all systems in operation (including window heater)
- Cable Entries: 2x conduit entries 3/4" 14NPT or M25x1.5
- Wiring: 12-20AWG (2.5-0.35mm²)

6.3 Outputs

- Relays: Volt-free contacts rated 2A at 30 VDC
 - Alarm: Normally open
 - Fault²: Normally open energized

² The FAULT relay will normally be energized and the contact will be closed during normal operation of the detector. The contact will be open at fault condition or low voltage.

- 0-20mA (stepped) current output: 3 wire and 4 (isolated) wire configurations (sink and source).

The 0-20 mA output at different detectors status are define at the below table.

The max load of 0-20 is max 500 ohm at 18-32 VDC. The 0-20 mA is sink isolated and can be configured as source.

Detector status	Output
Fault	0 mA or 1 mA \pm 10%
BIT fault	2 mA \pm 10%
Normal	4 mA \pm 10%
IR Detected	8mA \pm 10%
UV Detected	12mA \pm 10%
Alarm	20 mA \pm 5%

- Tri-colour LED indication
- Modbus RTU compatible protocol on RS-485

6.4 Mechanical Specifications

- Size: 5.51 x 3.54x 3.54" (140x90x90mm)
- Weight:
 - Detector (Stainless Steel 316): 6.6 lbs. (3 kg)
 - Tilt mount (Stainless steel 316): 3.3 lbs. (1.5 kg)

6.5 Environmental Specifications

- Temperature Range:
 - Operating -67°F to + 167°F (-55°C to +75°C)
 - Option -67°F to + 185°F (-55°C to +85°C)
 - Storage -67°F to + 185°F (-55°C to +85°C)
- Humidity: up to 99%, non-condensing
- Ingress Protection: IP66 & 68 (2m, 24hr); NEMA 4X & 6P

6.6 Label Figures

6.6.1 Ex db

P/N	FLS-888-888	S/N	888888	Mfg. Date	MMM YYYY
ICQC 19 ATEX 0424 X					
Ex db IIC T5 Gb Ex tb IIIC T95°C Db -55°C<Ta<75°C Ex db IIC T4 Gb Ex tb IIIC T105°C Db -55°C<Ta<85°C IP66 & 68 (2m, 24hr)					
FM19CA0035X	Class I, Div. 1, Groups B, C & D; T4 Class I, Zone 1, AEx/Ex db IIC T4 Gb T4 -50°C≤Ta≤85°C T5 -50°C≤Ta≤75°C				
IECEX FMG19.0015X	Ex db IIC T4 Gb T4 -50°C≤Ta≤85°C T5 -50°C≤Ta≤75°C				
Type 4X/6P Vin: 18-32 VDC Imax: 180mA Standby: 120mA					
Fire & Gas Detection Technologies 590 Central Ave., Suite K Brea, CA USA					

⚠ Warning / Attention

Read and understand instruction manual before operating. Do not open when an explosive atmosphere is present. Seal All Conduits within 18 inches. Do not open when energized.

Lire et comprendre le manuel d instruction avant l' utilisation. Ne pas ouvrir quand une atmosphère explosive est présente. Sceller tous les conduits pour les 18 pouces. De pas ouvrir lorsqu'il est sous tension.

6.6.2 Ex db eb

P/N	FLS-XXX-XXX	S/N		Mfg. Date	MMM-YYYY
ICQC 19 ATEX 0424 X					
Ex db eb IIC T5 Gb Ex tb IIIC T95°C Db -55°C<Ta<75°C Ex db eb IIC T4 Gb Ex tb IIIC T105°C Db -55°C<Ta<85°C IP66 & 68 (2m, 24hr)					
FM19CA0035X	Class I, Div. 1, Groups B, C & D; T4 Class I, Zone 1, AEx/Ex db IIC T4 Gb T4 -50°C≤Ta≤85°C T5 -50°C≤Ta≤75°C				
IECEX FMG19.0015X	Ex db IIC T4 Gb T4 -50°C≤Ta≤85°C T5 -50°C≤Ta≤75°C				
Type 4X/6P Vin: 18-32 VDC Imax: 180mA Standby: 120mA					
Fire & Gas Detection Technologies 590 Central Ave., Suite K Brea, CA USA					

⚠ Warning / Attention

Read and understand instruction manual before operating. Do not open when an explosive atmosphere is present. Seal All Conduits within 18 inches. Do not open when energized.

Lire et comprendre le manuel d instruction avant l' utilisation. Ne pas ouvrir quand une atmosphère explosive est présente. Sceller tous les conduits pour les 18 pouces. De pas ouvrir lorsqu'il est sous tension.

6.7 Approvals

Note: All items are designed and tested to meet the relevant requirements.

- Explosion proof:
 - ATEX: II 2 G D
 Ex db IIC T5 Gb or Ex db eb IIC T5 Gb and Ex tb IIIC T95°C Db -55°C<Ta<75°C
 Ex db IIC T4 Gb or Ex db eb IIC T4 Gb and Ex tb IIIC T105°C Db -55°C<Ta<85°C
 - IECEx:
 Ex db IIC T5 Gb -50°C≤Ta≤75°C
 Ex db IIC T4 Gb -50°C≤Ta≤85°C
 - FM & FMC:
 Class I, Div. 1, Groups B, C & D; T4
 Class I, Zone 1, AEx/Ex db IIC T4 Gb
 T4 -50°C≤Ta≤85°C
 T5 -50°C≤Ta≤75°C
- Performance:
 - ANSI FM 3260
 - EN 54-10 (pending)
- Functional safety (pending): SIL 2 per IEC 61508
- DNV GL (pending):
 Standard DNVGL-CG-0339 for open deck locations
 Temperature class D; Vibration Class A, B and C
- EAC CU TR (pending)

6.8 Electromagnetic Compatibility

The detector fully complies with EMC directive 2014/30/EU and protected against interference caused by RFI and EMI. The cables to the detector must be shielded and the detector must be grounded in order to comply to the EMC directive.

7 Warranty

FIRE & GAS DETECTION TECHNOLOGIES INC. agrees to extend to Purchaser/Distributor a warranty on the FIRE & GAS DETECTION TECHNOLOGIES INC. supplied components of the FlameSpec products. FIRE & GAS DETECTION TECHNOLOGIES INC. warrants to Purchaser/Distributor that the products are free from defects in materials and workmanship for a period of five (5) years, commencing with the date of delivery to Purchaser/Distributor. FIRE & GAS DETECTION TECHNOLOGIES INC. expressly excludes damage incurred in transit from the factory or other damage due to abuse, misuse, improper installation, lack of maintenance or "Act of God" which are above and beyond its control. FIRE & GAS DETECTION TECHNOLOGIES INC. will, upon receipt of any defective product, transportation prepaid, repair or replace it at its sole discretion if found to have been defective when shipped. Said repair or replacement is FIRE & GAS DETECTION TECHNOLOGIES INC. sole liability under this warranty and FIRE & GAS DETECTION TECHNOLOGIES INC. liability shall be limited to repair or replacement of the component found defective and shall not include any liability for consequential or other damages. The customer is responsible for all freight charges and taxes due on shipments both ways. This warranty is exclusive of all other warranties express or implied.

Appendix A Response Characteristics FLS-UV-IR

A.1 Response to different fire scenarios

The following tables show test results of detection distances and times for different fire scenarios. Each table lists results for a different sensitivity setting. For liquid fires the size of fire refers to the size of the pan, filled with the fuel. For gas fires the length of the plume is listed.

Extreme Sensitivity

Fuel	Size	Distance Feet (m)	Average Response Time (Seconds)
N-Heptane	1 x 1 ft	98 (30)	2.0
Gasoline	2 x 2 ft	197(60)	3.3
Gasoline	1 x 1 ft	98 (30)	1.8
Methane	32-in Plume	59 (18)	1.4
LPG	32-in Plume	75 (23)	1.2
Diesel	1 x 1 ft	75 (23)	2.6
JP5	1 x 1 ft	75 (23)	3.3
Kerosene	1 x 1 ft	75 (23)	1.8
Methanol	1 x 1 ft	52 (16)	0.8
Ethanol	1 x 1 ft	62 (19)	4.1
Isopropanol	1 x 1 ft	75 (23)	2.2
Polypropylene	1 x 1 ft	49 (15)	1.4
Paper	1 x 1 ft	33 (10)	1.2
H2	32-in Plume	66 (20)	6.4

High Sensitivity

Fuel	Size	Distance Feet (m)	Average Response Time (Seconds)
N-Heptane	1 x 1 ft	75 (23)	1.7
LPG	32-in Plume	56 (17)	1.6
JP5	1 x 1 ft	56 (17)	1.8
Methanol	1 x 1 ft	43 (13)	3.2

Medium Sensitivity

Fuel	Size	Distance Feet (m)	Average Response Time (Seconds)
N-Heptane	1 x 1 ft	49 (15)	1.0
Gasoline	1 x 1 ft	49 (15)	1.3
Methane	32-in Plume	30 (9)	0.9
LPG	32-in Plume	33 (10)	1.2
Diesel	1 x 1 ft	36 (11)	1.2
JP5	1 x 1 ft	36 (11)	1.2
Kerosene	1 x 1 ft	36 (11)	0.9
Methanol	1 x 1 ft	30 (9)	1.3
Ethanol	1 x 1 ft	31 (9.5)	2.9
Isopropanol	1 x 1 ft	36 (11)	0.8
Polypropylene	1 x 1 ft	23 (7)	0.9
Paper	1 x 1 ft	23 (7)	1.0
H2	32-in Plume	33 (10)	1.0

Low Sensitivity

Fuel	Size	Distance Feet (m)	Average Response Time (Seconds)
N-Heptane	1 x 1 ft	16 (5)	1.0
LPG	32-in Plume	13 (4)	1.2
JP5	1 x 1 ft	16 (5)	1.2
Methanol	1 x 1 ft	10 (3)	2.7

A.2 False Alarm Immunity

The following table shows test results of false alarm immunity for detectors configured to “Extreme” sensitivity. For each radiation source a distance is listed. This is the minimum tested distance, from which the detectors did not alarm when exposed to the radiation source (either modulated or non-modulated).

False Stimuli only at Extreme Sensitivity

False Alarm Source	Maximum Distance in ft (m)
Sunlight, Direct, Reflected	
Incandescent frosted glass light, 300W	2 (0.5)
Fluorescent, 70W (3x23.3W)	2 (0.5)
Electric arc	2 (0.5)
Arc welding	10 (3)
Radiation heater, 1850W	2 (0.5)
Quartz lamp (1000W) shielded	2 (0.5)
Quartz lamp (500W) non-shielded	7 (2)
Mercury vapor lamp 160Wx3	2 (0.5)
Car Exhausts	2 (0.5)
Projector led	2 (0.5)
Solenoid bell	2 (0.5)
Soldering iron	2 (0.5)
Electric Drill	2 (0.5)

Appendix B Response Characteristics FLS-UV-IR-F

B.1 Response to different fire scenarios

The following tables show test results of detection distances and times for different fire scenarios. Each table lists results for a different sensitivity setting. For liquid fires the size of fire refers to the size of the pan, filled with the fuel. For gas fires the length of the plume is listed.

Extreme Sensitivity

Fuel	Size	Distance Feet (m)	Average Response Time (Seconds)
N-Heptane	1 x 1 ft	98 (30)	3.2
Gasoline	2 x 2 ft	197(60)	5.3
Gasoline	1 x 1 ft	98 (30)	3.4
Methane	32-in Plume	59 (18)	1.6
LPG	32-in Plume	75 (23)	1.2
Diesel	1 x 1 ft	75 (23)	4.3
JP5	1 x 1 ft	75 (23)	7.0
Kerosene	1 x 1 ft	75 (23)	2.9
Methanol	1 x 1 ft	59 (18)	3.6
Ethanol	1 x 1 ft	72 (22)	4.5
Isopropanol	1 x 1 ft	75 (23)	2.8
Polypropylene	1 x 1 ft	49 (15)	1.8
Paper	1 x 1 ft	33 (10)	2.6

High Sensitivity

Fuel	Size	Distance Feet (m)	Average Response Time (Seconds)
N-Heptane	1 x 1 ft	75 (23)	1.6
LPG	32-in Plume	56 (17)	1.6
JP5	1 x 1 ft	56 (17)	2.3
Methanol	1 x 1 ft	43 (13)	1.2

Medium Sensitivity

Fuel	Size	Distance Feet (m)	Average Response Time (Seconds)
N-Heptane	1 x 1 ft	49 (15)	1.4
Gasoline	1 x 1 ft	49 (15)	2.7
Methane	32-in Plume	30 (9)	0.9
LPG	32-in Plume	33 (10)	1.3
Diesel	1 x 1 ft	36 (11)	1.6

JP5	1 x 1 ft	36 (11)	1.5
Kerosene	1 x 1 ft	36 (11)	1.4
Methanol	1 x 1 ft	30 (9)	1.3
Ethanol	1 x 1 ft	31 (9.5)	1.2
Isopropanol	1 x 1 ft	36 (11)	1.4
Polypropylene	1 x 1 ft	23 (7)	1.7
Paper	1 x 1 ft	23 (7)	2.0

Low Sensitivity

Fuel	Size	Distance Feet (m)	Average Response Time (Seconds)
N-Heptane	1 x 1 ft	16 (5)	0.9
LPG	32-in Plume	13 (4)	1.0
JP5	1 x 1 ft	16 (5)	2.6
Methanol	1 x 1 ft	10 (3)	1.1

B.2 False Alarm Immunity

The following table shows test results of false alarm immunity for detectors configured to “Extreme” sensitivity. For each radiation source a distance is listed. This is the minimum tested distance, from which the detectors did not alarm when exposed to the radiation source (either modulated or non-modulated).

False Stimuli only at Extreme Sensitivity

False Alarm Source	Maximum Distance in ft (m)
Sunlight, Direct, Reflected	
Incandescent frosted glass light, 300W	2 (0.5)
Fluorescent, 70W (3x23.3W)	2 (0.5)
Electric arc	2 (0.5)
Arc welding	10 (3)
Radiation heater, 1850W	2 (0.5)
Quartz lamp (1000W) shielded	2 (0.5)
Quartz lamp (500W) non-shielded	7 (2)
Mercury vapor lamp 160Wx3	2 (0.5)
Car Exhausts	2 (0.5)
Projector led	2 (0.5)
Solenoid bell	2 (0.5)
Soldering iron	2 (0.5)
Electric Drill	2 (0.5)

Contact us

Fire & Gas Detection Technologies, Inc

590 W Central Ave, Brea, CA 92821, USA

Tel: (+1) 714 671 8500

Email: support@fg-detection.com